

Arizona Vortex Tube Mfg. Co.

Vortex Tube Dimensions Inches and Millimeters

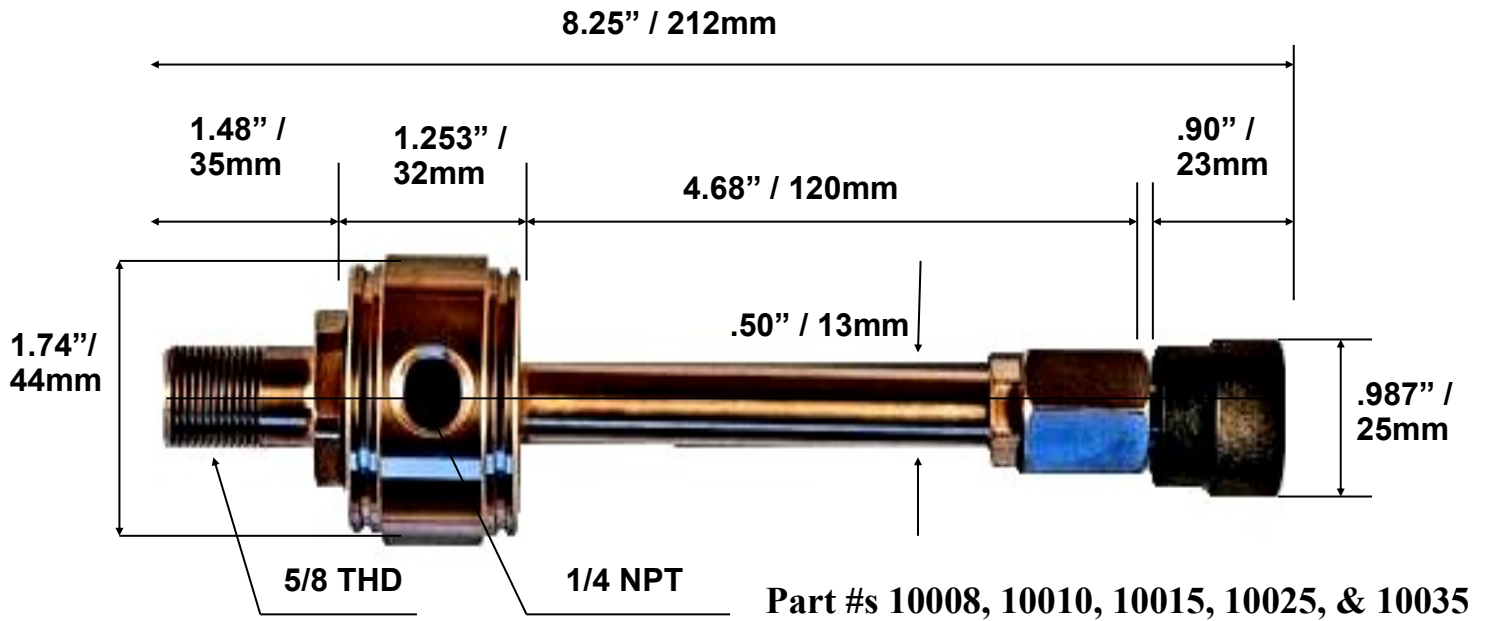



Vortex Tube Installation and Maintenance

Vortex Tube Assembly

1. Cold End Cap
2. O-Ring
3. Generator (not pictured is the brass taper sleeve which would go in before the generator into the spin chamber)
4. Spin Chamber
5. Hot End Valve Assembly

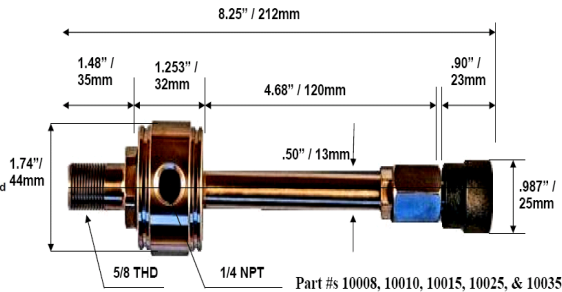
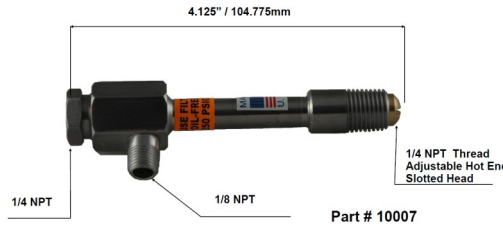
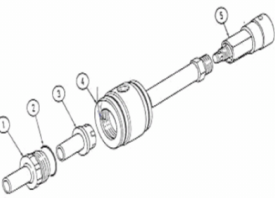

Compressed Air Supply Line Sizes:

To obtain maximum performance from the Arizona Vortex products, measurements of pressure (psig) and volume (scfm) of air must be obtained. Pressure drops in the compressed air lines should be held at a minimum. Quick connects can “starve” the vortex tube by causing excessive line pressure drops. Do not use plastic tubing. The chart below is suggested lines sizes for pipes and hoses.

Line Sizes for Runs Up To:	10 Ft (3m)		10 - 50 Ft (3 - 15m)		50 - 100 Ft (15 - 31m)	
	Pipe	Hose	Pipe	Hose	pipe	hose
Model 10007	1/8"	1/4"	1/4"	3/8"	1/4"	3/8"
Models 10008-10035	1/4"	3/8"	3/8"	1/2"	1/2"	5/8"

Compressed Air Supply:

Air lines are plagued with condensed water vapor, oil or oil vapor in the air lines. This condensation leads to rust and debris in the air lines. Small orifices in the Arizona Vortex Tube may become clogged with rust, dirt, and water droplets from these unfiltered air supplies. A 5-micron filter will separate 99% of the foreign matter from the air supply, allowing virtually maintenance free operation. The use of an oil filter with an effective filtration of 0.01 ppm will remove the oil droplets for an even cleaner air supply. Air filter part # 90000 can be used with all Arizona Vortex Tubes and other applied models. The Oil coalescing filter part # 90020 can be used along with the air filter for all Arizona Vortex Tube Products. Keep in mind that the current line or air hose might contain dirt or oil and should be blown out before installation. Also, pipe thread sealant or tape must be carefully applied to avoid clogging product orifices.

Using The Vortex Tube - Generators:

The Arizona Vortex generator determines the volume of air through the Vortex Tube. The generator is an internal plastic part already installed in the Vortex Tube. These generators are rated for 8, 10, 15, 25, and 35 scfm at 80 psig. To ensure that your air compressor can generate these volumes, the horsepower of the compressor can be multiplied by four to determine the scfm capacity. A multiple of 5 can be used on newer compressors.

The Arizona Vortex Application Development kit part # 10040 contains an Arizona Vortex Tube, all generators, and air filter. To change the generator and thus the volume of air, simply remove the cold cap using a 1" crescent wrench. Pull out the “O” ring and generator and replace it with the desired generator. Then reassemble the “O” ring and cold cap tightly. The percentage of the incoming air, from the compressed air supply, exiting from the cold end is the cold fraction. The Arizona Vortex generator determines the scfm. Therefore, using a 10 scfm generator with a cold fraction of 60 %; means 6 scfm of air out the cold end and 4 scfm out the hot end. The cold fraction can be changed by turning the hot end valve. There always has to be some air flowing through the hot end to create cooling. By turning the hot end valve between 1 and 1 ½ turns the cold end air temperature will be at its lowest point.

Adjusting The Vortex Tube:

Adjusting the hot and cold temperatures can be done using the slotted valve with model # 10007 and with the black adjusting knob on model #'s 10008 - 10035. Rotating the valve counter clockwise will reduce the cold airflow and the cold air temperature. You can set the Vortex Tube with a thermometer. In order to achieve accurate temperatures the thermometer should be inserted into the cold end muffler or into a piece of flexible tubing on the cold end side.

Ducting the Air:

The air existing from the cold end or hot end is just above atmosphere pressure. It is important to use a tube, when ducting the air that is at least as large as the outlet of the Arizona Vortex Tube. Also, since outlet pressure is low, restricting the ducted air through a small nozzle or into a container will create back pressure and cause poor cooling or heating performance. Noise should not be an issue if the hot and cold ends are ducted. Mufflers are available for both cold and hot ends.

Cleaning and Maintenance:

The Arizona Vortex Tube has no moving parts. Clean compressed air moving through the tube will not cause wear on the parts and will provide you with the same reliable service for an indefinite period of time.

<i>Trouble-Shooting Common Issues if the Vortex Tube has poor performance</i>	<i>Action to Take:</i>
Loose Cold Cap	The cold end cap should be on the Vortex Tube tight. Use a 1" crescent wrench to tighten the cold end cap.
Incoming Air Pressure	Low pressure will cause poor performance. Take a measurement of pressure just before the Vortex Tube. Extended lengths of air hose can cause pressure drops and lower performance.
Incoming Air Temperatures	The Vortex Tube drops temperature from the compressed air supply. Supply lines may be warmer than ambient if the lines run across the ceiling or near heat ducts.
No Cold Air	Occasionally, dirt, water, or oil may enter the tube from the compressed air supply and hinder the performance. When this happens, simply take the unit apart, clean the parts, and reassemble, tightly replacing the cold end cap to properly seat the generator. When the temperature of the air inside the Arizona Vortex Tube reaches 32° F. (0° C.), the water vapor in the air will start to freeze. If this poses a problem with ice clogging the orifices of the generator inside the tube, an air dryer must be used to lower the dew point to keep out the water vapor. A dryer rated at -35° F will produce a dew point low enough to eliminate the water vapor freezing in the orifices of the generator.
Back Pressure	Make sure your ducting is at least as large as the outlet. Pressure up to 2 psig (.1BAR) should not alter performance. Pressure of 5 psig (.3 BAR) will alter the performance by approximately 5°F (2.8°C).

Questions or Concerns:

Toll Free: 1-800-660-4060

Worldwide: 1-928-684-5733

FAX: 1-928-684-5752

Email: info@arizonavortex.com

Website: www.arizonavortex.com