

Servo and VFD Motor EMI Filters

Improve Reliability of Your Motors Reduce Electrical Overstress (EOS) Reduce Electromagnetic Interference (EMI)

Operation of servo and variable frequency motors causes a number of problems in a tool, including damage to the motor's bearings from leakage currents. Another problem caused by this noise is errors in operation of electronic equipment, including test and metrology. Sensitive electronic components processed on such tools as IC handlers, wire bonders, SMT pick-and-place machines and many others can be subject to electrical overstress (EOS) caused by noise from servo motors, affecting yield and reliability.

OnFILTER servo motor EMI filters perform two important functions: they substantially reduce high-frequency noise within the tool resulting from operation of servo and variable frequency motors and improve reliability of motors by reducing leakage current through their bearings.

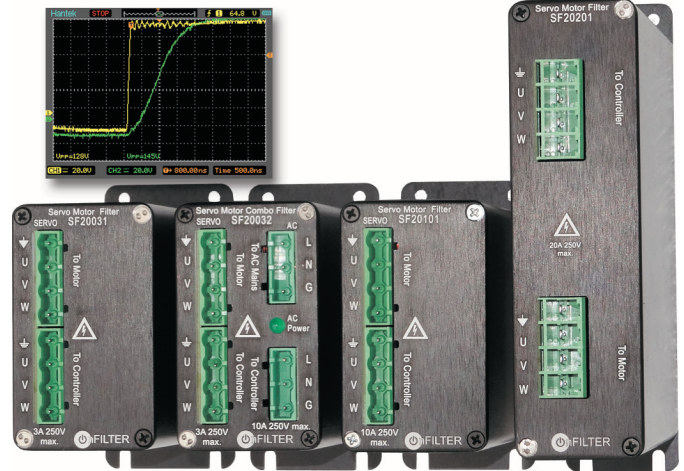

Applications

- Industrial robotics
- Semiconductor fabrication
- Electronic assembly
- Disk drive manufacturing
- Military
- Wherever EOS and EMI are a problem

Features

- Greatly reduced noise from servo motor operation
- Easy plug-in installation
- Drive and AC filtering in some models
- Optimized for most servo motors
- Effective management of rise and fall times of drive pulses
- Proprietary reduction of ground current

Reduced Ground Noise

OnFILTER servo EMI filters greatly reduce high-frequency noise on ground and overall noise in the tool which lowers risk of EOS to sensitive components

Less Errors in Equipment

Reduced electrical noise means less errors in operation of sensitive electronics, including test and metrology equipment. Less errors and lock-ups in test and handling improves your bottom line

Improved Reliability of Servo Motors

OnFILTER' servo motor filters stretch rise and fall times (dV/dt) of the drive pulses dramatically reducing leakage through the motor bearing. Proprietary patent-pending technology further reduces leakage currents beyond capabilities of only dV/dt filters, preventing deterioration of bearings leading to the motor's premature failure.

Complete Noise Suppression

Some models include a patent-pending combination of motor and AC filtering which greatly reduces interference from servo drive on the tool.

Servo and VFD Motor EMI Filters

- SF20031
- SF20032
- SF20101
- SF20201



Specification

OnFILTER servo filters utilize proprietary technology to provide maximum noise suppression and reduce high-frequency currents from servo and variable frequency motor operation.

Parameter	SF20031	SF 20032	SF20101	SF20201
DRIVE FILTER				
Drive Voltage, max.	250V	250V	250V	250V
Drive Current, max.*	3A	3A	10A	20A
Rise/Fall Times, typ.	1.5 μ S	1.5 μ S	1.2 μ S	1.2 μ S
AC FILTER				
AC Voltage, max.	N/A	250VAC	N/A	N/A
AC Current, max.	N/A	10A	N/A	N/A
Noise Reduction, typ.	N/A	>20dB	N/A	N/A
Nominal DC Resistance	<0.2 Ω	<0.2 Ω	<0.2 Ω	<0.2 Ω
Dimensions w/plug-ins				
Width	1.85"	1.85"	1.85"	1.56"
	47mm	47mm	47mm	39.6mm
Height	4.0"	4.0"	4.0"	6.45"
	102mm	102mm	102mm	164mm
Depth	5.87"	5.87"	5.87"	7.22"
	150mm	150mm	150mm	183.4mm
* at duty cycle (motor exerting max. torque) of 20%				

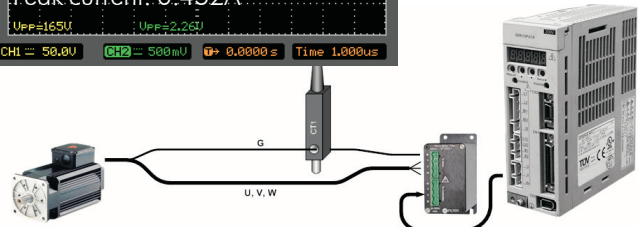
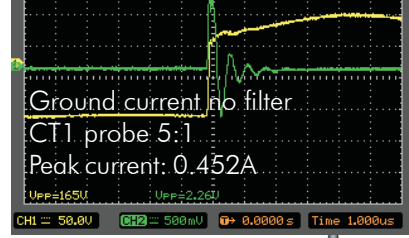
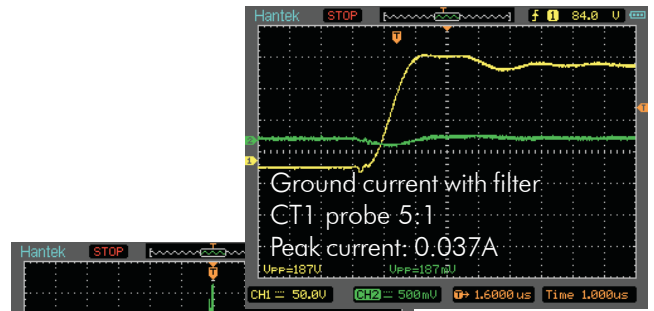

OnFILTER' servo motor EMI filters use patent-pending technology to reduce ground current which is a source of damage to the motor and of significant EOS in the tool.

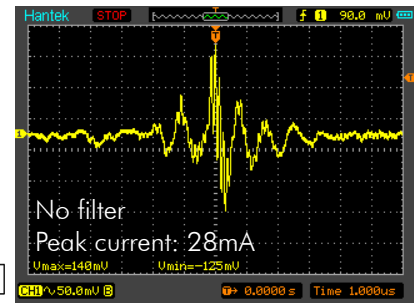
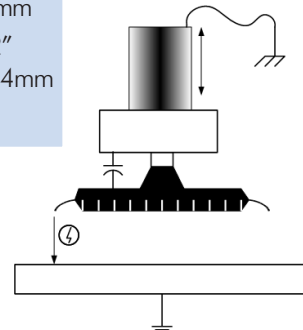

Servo motors introduce strong currents through the devices causing electrical overstress. OnFILTER' servo motor EMI filters can reduce EOS-causing currents down to insignificant levels

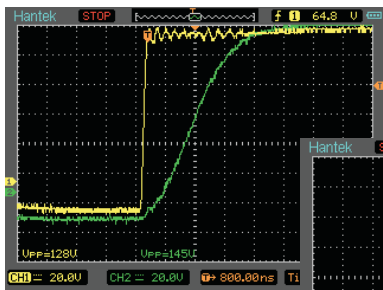
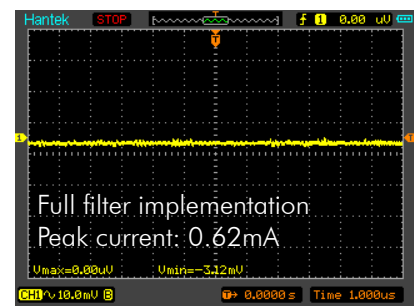

Typical modification of edge of the drive pulse

Reduction of drive signal artifacts

Ordering Information

OnFILTER' servo motor EMI filters work with the majority of servo/variable frequency controllers and motors. You would need to know just two parameters: max. drive voltage and current - both are typically indicated on a label of the motor itself, or on the servo amplifier. Do not exceed specified maximum rating of the filter as this may damage the filter itself, the motor, the servo controller and possibly your tool as well.

Model	Motor	AC Power
SF20031	250V 3A	N/A
SF20032	250V 3A	250VAC 10A Single Phase
SF20101	250V 10A	N/A
SF20201	250V 20A	N/A

Contact us for other configurations



OnFILTER, Inc.
 730 Mission St. Ste.102
 Santa Cruz, CA 95060 U.S.A.
 Tel. +1.831.824.4052
 FAX +1.206.350.7458
 www.onfilter.com
 info@onfilter.com